

we care 

primus

laundry equipment

## Industrial Dryers

D 55, D 77



### FEATURES

- Easy-to-use electronic programmer
- Dryness level setting is a standard feature on the electronic programmer
- Gas or steam heating
- Large door opening for easy loading and unloading (Ø62cm)
- Standard reversing drum
- Self-cleaning lint screen
- Preheating of intake air

### OPTIONS

- Stainless steel drum



LOW ENERGY  
CONSUMPTION



LARGE DOOR  
OPENING



FAST DRYING  
CYCLES

TYPE		D 55 GAS	D 55 STEAM (HIGH PRESSURE)	D 77 GAS	D 77 STEAM (HIGH PRESSURE)
CAPACITY	kg	55		77	
DIMENSIONS DRUM					
Drum volume	m <sup>3</sup>	1,025		1,408	
Drum	mm	Ø1118×1041		Ø1289×1080	
AIR FLOW	l/s	755		1156	
HEATING	kW	88	119	116	190
MOTOR					
Drum	kW	0,552		0,552	
Fan	kW	0,736		2,208	
CONNECTION					
Electrical 380-400V	AC/Hz	3+N/50 Others on request		3+N/50 Others on request	
Gas inlet	inch	3/4	-	1	-
Steam inlet	inch	-	3/4	-	1 1/4
Air outlet	mm	254		300	
	inch	10		12	
DIMENSIONS					
H×W×D unpacked	mm	2177×1178×1725	2121×1178×1725	2388×1349×1749	2388×1349×1749
H×W×D packed	mm	2300×1300×1820	2300×1300×1820	2520×1480×1910	2520×1480×1910
WEIGHT					
Net	kg	580	625	716	761
Gross	kg	655	700	871	836

The data concerning dimensions of machines include all extended parts

**FRONT D 55 77**

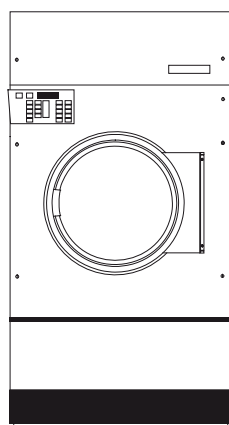

**SIDE D 55 77**

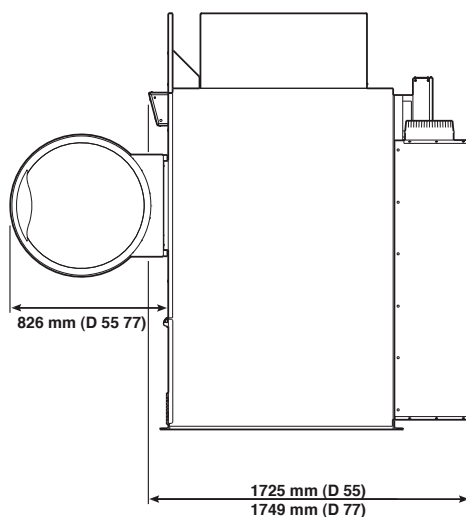

**BACK D 55 77**

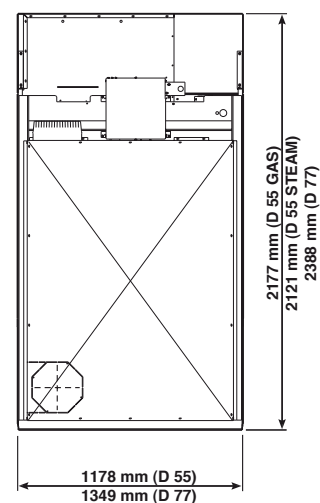

The company Primus preserves the right to change the machines and the specification in this leaflet at any time, without prior notice. Details and photographs are only for information and never binding.

[www.primuslaundry.com](http://www.primuslaundry.com)

ISO 9001  
ISO 14001  
BUREAU VERITAS  
Certification

